



Automated Fiber Management  
for Datacenters and Networks

# Enabling New Services Through Automated Fiber Management (AFM)

## Case Study

[ [www.fiberzone-networks.com](http://www.fiberzone-networks.com) ]





## About the MTDC Market

Multitenant data centers (MTDCs) are facilities that are typically owned by firms specializing in providing Internet infrastructure services to customers. These services include electrical power, cooling, fire suppression, security, and network access usually provided over optical fiber. Some firms lease datacenter space to other providers, as well as to individual enterprises. Colocation datacenters sell space on the basis of racks, cabinets or cages to a range of customers.

According to Tier1Research, a New York-based research and advisory firm specializing in MTDCs, the market has remained strong throughout the global recession and initial stages of recovery. In fact, many MTDC firms have achieved double-digit growth per quarter since 2008, thanks to strong growth in Internet traffic and an increased demand for non-capital-intensive expansion facilities. Increased requirements for MTDC space is expected to continue through 2013.

Market demand for MTDC space currently exceeds supply in most global markets, and it is expected that demand will increase twice as fast as supply through 2014. This provides the potential for MTDCs to represent a very lucrative market in the years ahead. It will also generate strong competition among MTDC operators who must find new and innovative ways to differentiate their services from those of their competitors.

## Challenges Face Today's Mode of Operation

Today's typical MTDC operator provides co-location at optimal locations for interconnection between

enterprise networks and their tenant customers. Customers range from large enterprises with significant IT expertise and requirements to Internet content providers and content delivery networks.

Most MTDCs can offer full facility maintenance and systems, including fire suppression, security, power backup, and heating/cooling. Some offer additional services such as remote hands technician services and network monitoring services. Today, the only significant differentiator between MTDCs is location. A second might be which providers are available for interconnection. But there is still very little differentiation among MTDCs in a market that is attracting new players and stiffer competition. Therefore, as the supply and demand curve begins to flatten out in the coming years, MTDC operators must seek new services to differentiate themselves from simply offering real estate and power. These new services can help MTDC operators to meet the competitive challenges that lie ahead and even increase their bottom line through new opportunities - ensuring them to squeeze the most possible revenue from their new or existing facilities.

## Introducing: Automated Fiber Management (AFM)

FiberZone's Automated Fiber Management (AFM) product line provides MTDC operators the ability to offer new revenue-generating services to their customers. This product line was designed specifically to automate, switch and manage fiber infrastructure for dramatically reducing total cost of ownership (TCO) and removing the main barriers for networks to scale. FiberZone's product line consists of best-in-class physical layer switch hardware, carrier-grade software and management modules, and a set of open interfaces for integration with third-party management systems.

The AFM product line features FiberZone's Latched Optical Coupling (LOC™) technology that was developed specifically to address fiber management applications, including the challenges faced by MTDC operators in expanding their service offerings. The principle of LOC™ is to physically couple two optical fibers together without mirrors, lenses, or collimators. Once a physical connection is made, it does not require continuous power to maintain connectivity, and guarantees optical performance similar or better than that of traditional patch panels under all circumstances.

FiberZone's AFM allows an MTDC operator to remotely switch fiber links in minutes, provides remote connectivity management capabilities, maintains accurate fiber records, and provides test access capability for troubleshooting and locating faults. Fiber switching, management and troubleshooting can be accomplished from a central location, operated by highly-qualified staff, without the need to dispatch an urgent truck roll.

FiberZone's AFM solution offers a compelling value proposition to MTDC operators faced with the task of controlling the TCO of their fiber infrastructure. It enables them to:

- Reduce time and cost to provision new services by an order of magnitude
- Avoid revenue loss and SLA penalties due to delays and mis-configurations
- Provide new service offerings to their customers, including time-of-day and even-based provisioning and turn-up
- Eliminate limitations posed by local hosting providers on access to equipment and infra structure
- Remotely troubleshoot faults by highly-qualified technical staff and reduce mis-repairs and human errors
- Decouple network maintenance from service delivery

Other benefits that are unique to FiberZone's AFM solution for MTDC operators include:

## KEY BENEFITS

- Enable new value-add services to MTDC tenants to drive new revenues and differentiation
- Streamline provisioning of new cross-connects and reduce turnaround time
- Reduce operational expenses
- Eliminate cost of downtime by enabling expedited cross-connects
- Facilitate 'lights-out' operation using remote configuration and control

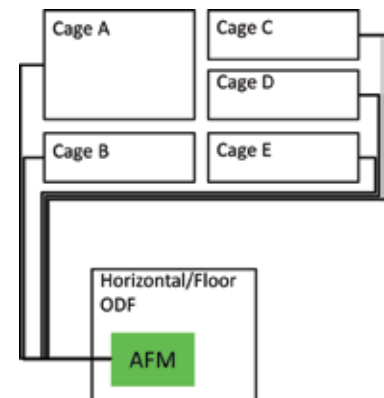

- FiberZone's patented LOC™ technology means that fiber connections stay connected in complete power failure situations or during system maintenance and servicing
- FiberZone's AFM is the only solution to provide completely transparent switching and management of fiber infrastructure - independent of fiber type, bit rate and type of traffic carried over the fibers, and whether it's lit or unlit (dark) fiber
- FiberZone's AFM is the only solution to offer optical performance comparable or better than a standard patch panel

## New Service Opportunities with AFM

With FiberZone's AFM solution, MTDC operators are able to launch an array of new services to their co-located customers. The opportunity is two-fold - differentiation from competitors and increased revenues generated from cutting-edge high-margin services. Let's take a look at five new services enabled by FiberZone's AFM

### Emergency/Expedited Cross-Connect Service

Today, enterprise tenants do business by selecting their preferred carriers for inter-connection. The MTDC operator typically takes several days or more to complete a cross-connect between the tenant and carrier. The challenge with this mode of operation is that unpredictable events may sometimes require the tenant to switch to a different carrier co-located at the same MTDC. This situation played out during a recent earthquake and tsunami in Japan. The disaster created many network outages, and network operators found themselves scrambling to switch their tenant customers to other carriers that were still in service. Even though

some data was mission-critical, the turn-around took days, an unacceptable and costly situation for tenants. The availability of a premium Emergency Cross-Connect Service enables MTDC operators to offer rapid standby emergency connectivity to an alternate carrier in just minutes instead of days.

### Managed Cage Service

The current MTDC set-up leaves customers responsible for all intra-cage activity, including maintenance and troubleshooting. In some cases, operators enlist the help of smart hands services that assume responsibility for these activities. The additional cost and turn-around time for smart hands, not to mention loss of control and potential service level agreement (SLA) issues, makes this a less than optimal solution. Still, many enterprise customers prefer to have control over timing and change issues, opting to handle everything themselves. The opportunity provided by a Managed Cage Service using AFM gives operators the capability of remote, rapid and reliable management through a web interface. Revenues are increased by providing direct control to customers remotely at a lower cost to them. Operating costs are reduced through automation and, best of all, the service can be one more differentiator between the MTDC operator and its competitors.

### Carrier Exchange Service

The main value proposition for enterprises from MTDC operators is gaining access to wholesale carrier pricing. Enterprises that operate their own data centers from their own facilities typically are locked in to the pricing of the local exchange carrier that monopolizes the last mile. By co-locating to an MTDC facility, an enterprise's business is competed for by several carriers, enabling lower initial costs. However, once a carrier is selected, the cross-connect is a static connection that requires

significant turn-around time whenever an enterprise customer wants to switch to a lower-priced carrier. Carrier Exchange Service uses AFM to enable carriers to compete for enterprise business on a regular basis, taking advantage of prices that change daily or even hourly. Enterprise tenants can buy connectivity based on best pricing at any moment using a dynamic Carrier Exchange Services that increases the number of charged cross-connect at lower provisioning costs. This, in turn, increases the value of a co-location facility and creates one more differentiator for the MTDC operator.

## Temporary Cross-Connect Service for Public/Private Cloud Migration

Today, enterprises that want to migrate to public/private cloud services need a temporary cross-connect service to transfer large amounts of data as part of the migration. This same Temporary Cross-Connect Service can be used to perform routine data back-ups to remote locations. However, the carrier cost for a dedicated circuit used only for temporary data transfer by one enterprise customer is cost prohibitive. However, AFM provides a TemporaryCross-Connect Service solution that enables them to fill the role of provisioning temporary cross-connects on a regular basis to multiple tenants. Using AFM, MTDC operators can schedule temporary connections into a static carrier pipe as needed by the enterprise tenants. This increases the value of a co-located MTDC for both enterprise customers and carriers.

FiberZone's Automated Fiber Management (AFM) product line provides MTDC operators the ability to offer new revenue-generating services to their customers.

FiberZone's AFM allows an MTDC operator to remotely switch fiber links in minutes.

## Dark Fiber Service Protection

Dark fiber service is offered as an unprotected service in most MTDCs operating today. The restoration of faults requires manual physical re-provisioning in order to re-route traffic and create redundancy protection. MTDC operators have an opportunity to offer Dark Fiber Service Protection as a premium service to enterprise tenants, offering redundancy as a service across dark fiber to deliver protection for increased network availability - all managed and provisioned remotely by AFM. The result is guaranteed service availability, reduced downtime, less revenue losses, and remote management by highly-qualified technicians.

## The Business Case

Using AFM to provide new, revenue-generating, premium services enables MTDC operators to differentiate themselves by offering more than just real estate, power, and network connectivity. The costs of customer churn, provisioning circuits, mis-configurations and faults, repair times and human error, limited fiber links, and even routine maintenance add up to significant operational expense to the MTDC operator. Incorporating an AFM solution into the MTDC not only optimizes the services typically offered today, but provides the opportunity to introduce new services that will attract customers and differentiate one MTDC from another.

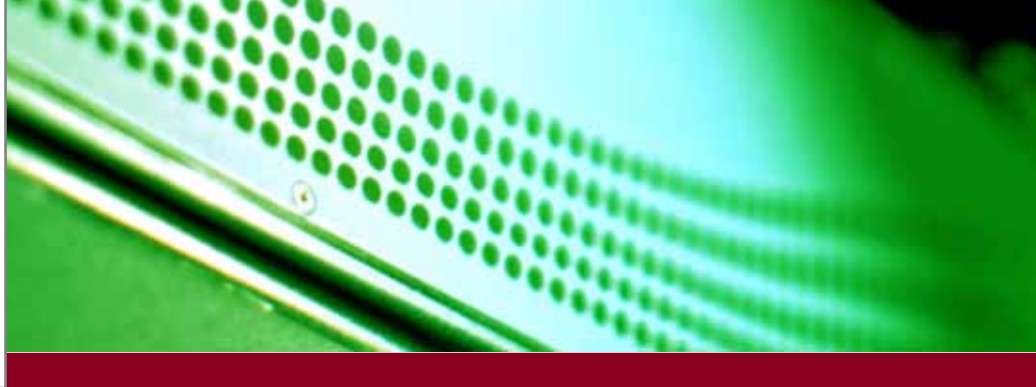

## About FiberZone Networks

FiberZone Networks delivers remote fiber connectivity solutions to datacenters and networks with its Automatic Fiber Management (AFM) product line, delivering reliability, flexibility, fault tolerance and management to the fiber infrastructure. FiberZone's AFM significantly increases network reliability and availability, reduces operating costs, minimizes network faults and human errors, and prevents revenue losses & SLA (Service Level Agreement) penalties. FiberZone's AFM product line utilizes patent-pending Latched Optical Coupling (LOC™) technology that delivers reliable passive connectivity in a remotely-managed automated fiber management system. FiberZone's AFM product line has been deployed by leading datacenter and network operators in the U.S., Asia, and Europe.



### Sales and Support Contact Information:

Americas Sales:	<a href="mailto:americasales@fiberzone-networks.com">americasales@fiberzone-networks.com</a>
India Sales:	<a href="mailto:indiasales@fiberzone-networks.com">indiasales@fiberzone-networks.com</a>
EMEA Sales:	<a href="mailto:emeasales@fiberzone-networks.com">emeasales@fiberzone-networks.com</a>
APAC Sales:	<a href="mailto:apacsales@fiberzone-networks.com">apacsales@fiberzone-networks.com</a>
Distribution and Partnerships:	<a href="mailto:bd@fiberzone-networks.com">bd@fiberzone-networks.com</a>

#### Israel:

2 Granit St., Kiryat-Aryeh  
P.O. Box 3026, Petach-Tikva, Israel 49130  
Tel: +972-74-7332200  
Fax: +972-74-7332211

#### Worldwide Headquarters:

7272 Wisconsin Avenue Suite 300, Bethesda, Maryland 20814 , USA  
Tel: 1-877-236-0313  
Email: [info@fiberzone-networks.com](mailto:info@fiberzone-networks.com)

[ [www.fiberzone-networks.com](http://www.fiberzone-networks.com) ]